

# Control of Pump Operation by Varying Rotational Speed in the Road Infrastructure

Leszek Szychta\*

Received November 2011

## Abstract

The paper evaluates applicability of pumping plants to road infrastructure. A comparative analysis is undertaken of the cascade control system of pump operation and the control system of pump operation by varying of rotational speed. The possibility of employing head of sewage in the storage reservoir to reduce energy consumption of pumping is a criterion of the analysis. Impact is discussed of the number of pumps in operation on energy efficiency and reliability of a pumping plant.

## 1. Introduction

Drainage of urban roads is necessary to provide surface durability and safety of use. In most road sections in actual operation, rainfall collectors are located in the immediate vicinity of transport routes. There are motorway sections and urban areas which form extensive basins where rainwater must be transported over considerable distances.

Rainwater is channelled into rain sewers which mostly take advantage of gravitation to cause free flow. In some locations, particularly in urban areas, rainfall waters are disposed of into the so-called combined sewage systems. Lie of the land may require forcing of sewage flows in drainage by means of sewage pumping plants in cases of:

- long, smooth road surfaces where rainwater collectors are not available in the vicinity,
- railroad stations in land hollows,
- walker or vehicle passages in land hollows,

---

\* Kazimierz Pułaski Technical University of Radom

- hollowed multi-level car parks,
- absence of natural rainfall collectors,
- grade separated junctions,
- extensive urban areas requiring construction of initial underground storage reservoirs.

Sewage pumping plants as part of rainwater or combined sewage systems are assemblies of equipment which are connected and cooperating with one another in order to dispose of sewage reliably and according to requirements [1, 2, 3, 4].

A pumping unit is a fundamental element of a pumping plant. It comprises a pumping assembly (engine) or a group of pumping sets in parallel between a suction and discharge branch as well as necessary electrical equipment and hydraulic fittings. A pumping set consists of a pump and electric drive which may include a motor, a frequency converter, a softstart system or a contactor. A pumping unit also comprises hydraulic fittings (pipelines, cut-off and check valves, manometers, diaphragm tanks), and a control system including monitoring and measurement devices (pressure converters, flow metres, ammeters), control (e.g. a PLC - Programmable Logic Controller) and safety equipment (e.g. sewage sensor, phase order sensor, etc.). A pumping unit is designed to pump sewage from a lower-pressure area to a higher-pressure area or to transport sewage to a distant reservoir.

A pumping unit is part of a specific engineering installation referred to as a pumping system or installation [5]. A pumping system is a broader concept than a pumping plant. It encompasses all elements working with a pumping plant, namely: storage reservoirs, sewage pipelines and installations.

A pumping plant (unit) and a pumping system are two interacting elements of a broadly-defined sewage system. The suction part of a plant contains a storage reservoir reached by sewage or rainwater. Sewage and occasionally rainwater flow through combined sewage systems. As sewage comes in, its level in the reservoir rises. The pumping plant is designed to pump such sewage out by turning on a pump (pumps). This will happen if the quantity of incoming sewage is lower than capacity of the plant. Automatic regulation of a pump's rotational speed helps to balance the plant's capacity and quantities of incoming sewage. A control system provides for enhanced energy efficiency and reliable operation of a pump.

Depending on function, two principal control systems can be distinguished:

- cascade,
- at variable rotational speed of one or several pumps.

Cascade control involves sequential switching of pump motors directly from the three-phase mains. At the time of controlling by means of frequency converters, one or more pumps in a unit operate at a variable rotational speed. This leads to varied pump capacities in order to maintain a constant head of sewage in a storage reservoir over a limited time span. This stabilisation of the head translates directly into improved energy efficiency of a pumping station.

## 2. Operating Principle of Sewage Pumping Plants

Rainwater can be pumped by immersion or dry pumps. Economic and space considerations usually require construction of immersion plants. A sample design of an immersion pumping plant made of polymer concrete PB and including two pumps is illustrated in Fig. 1.

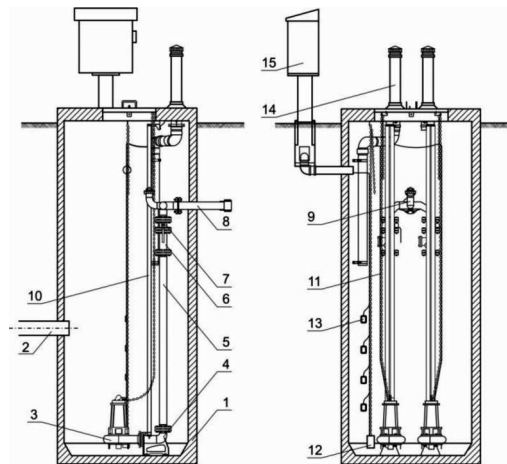

Fig. 1. Rainwater pumping plant made of polymer concrete PB, concrete BT or prestressed concrete BS; 1 – reservoir, 2 – duct for incoming sewage, 3 – immersion pump, 4 – coupling foot, 5 – pumping pipeline, 6 – check valve, 7 – cut-off valve, 8 – sewage disposal pipe, 9 – installation flushing connection, 10 – pipe guides, 11 – chains for lowering and lifting of pumps, 12 – weighted chain, 13 – floating switch, 14 – venting installation, 15 – control cabinet [6]

Material of the tank (1) is different in Figure 1. There are two pumps in the plant (3); in practice, single- or three-pump units are used as well (or even four-pump units in specific circumstances) as determined by engineering and economic analysis. Design of a pumping plant requires appropriate guides (10) and chains (11) to lift pumps for the duration of repairs. This requires the pumping branch to be cut off with a valve (7). In case of a pump's downtime, a check valve (6) prevents backfilling of the reservoir from the sewage disposal pipe (8). Sewage flows into the reservoir via the duct (2).

Pump operation is controlled in the control cabinet. The so-called cascade control system is applied to most cases, where a pump is switched depending on sewage level in the reservoir. Turnon and turnoff levels for a double-pump plant have been defined in Fig. 2. Pump operation is controlled by floating sensors P1 – P4 as a standard. A hydrostatic probe can also be used.

Operating condition of a pumping plant depends on a level of sewage in the reservoir. Level S1, corresponding to dry operation head  $h_m$ , triggers the pump to be switched off. Pump one is turned on by the floating switch P2 at level S2. Pump two is turned on by the floating switch P3 at level S3. This level corresponds to

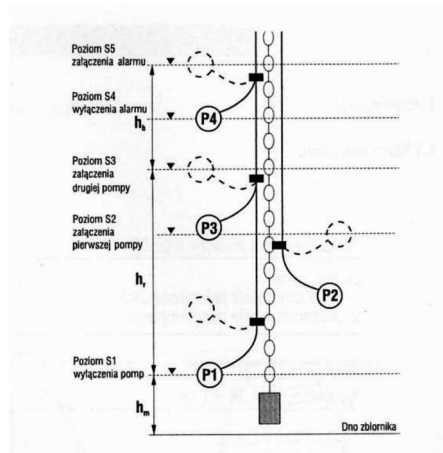

Fig. 2. Control levels of pumping plant's operation; P1 – dry operation sensor, P2, P3 – operation of pump one and two, P4 – alarm sensor [6]

head  $h_r$ , associated with the reservoir's retention capacity. As increased sewage quantities come in while capacity of two pumps in operation is insufficient, the sewage level in the reservoir continues to rise and the float P4 triggers the alarm at level S5. A limited capacity of pumps may be due to their breakdown, flow blockage by solid bodies, choking of the pumping branch, breakdown of the control system or wear and tear of a pump after years in operation. An alarm status requires an intervention by maintenance services [7].

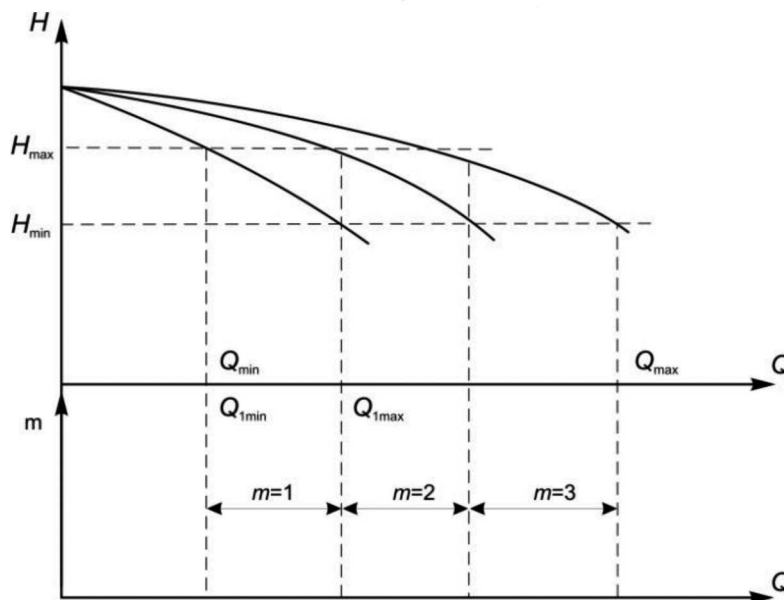

Fig. 3. Flow characteristic of a unit comprising  $m$  pumps

In a generalised case of the cascade control process described above,  $m$  identical pumps work at a nominal rotational speed  $n_N$  dependent on the quantity of sewage flowing out of a pumping plant  $Q_o$ . Flow characteristics of a pumping unit (Fig. 3) as dependent on  $m$  are determined by a dependence based on (1):

$$H = H_0 - A \frac{Q_o}{m} - B \left( \frac{Q_o}{m} \right)^2 \quad (1)$$

Variation range of pump heads, expressed as the difference between a maximum  $H_{\max}$  and a minimum  $H_{\min}$ , is a parameter in the cascade control process of a pumping plant. The stated  $H_{\min}$  and  $H_{\max}$  in a control system determine ranges of capacity variations,  $Q_{\max}$  and  $Q_{\min}$ . Maximum  $Q = Q_{1\max}$  of a pump ( $m = 1$ ), corresponding to a minimum head  $H = H_{\min}$ , is expressed as:

$$Q = \frac{\sqrt{A^2 + 4B(H_0 - H)} - A}{2B} \quad (2)$$

Minimum  $Q = Q_{1\min}$  for one pump ( $m = 1$ ) is defined by (2) for  $H = H_{\max}$ . The  $Q_{1\min}$  should provide for movements of solid particles in the pumping pipe, that is, the so-called suspension coagulation force should be generated. In practice, the flow rate is defined in line with the condition:  $V > 0.6$  [m/s] for rainwater. Where a pumping plant cooperates with combined sewage lines, the condition  $V > 0.8$  [m/s] ought to be fulfilled.  $Q_{1\min}$  and pumping pipeline diameter  $D_1$  are closely linked with the sewage flow rate:

$$V = \frac{Q_{1\min}}{900\pi D_1^2} \quad (3)$$

Pump capacities are frequently several times overdimensioned in practice as pipelines are occasionally designed with unreasonably excessive section diameters. By analogy, the need for rapid pumping of rainwater or sewage is often stipulated due to their putrescence. Such a solution may contribute to a quick pumping of sewage and, as a consequence of its continual inflow, to frequent pump switching during an hour.

The process of  $Q$  variations across a pumping plant composed of two identical pumps is shown in Fig. 4. One pump is assumed to operate initially in point A of the flow characteristic  $H_1(Q)$ . Capacity of the pumping plant is  $Q_{1\min}$  and the floating switch P1 is near the level S1, signifying imminent dry operation. After an assumed time interval  $\Delta t$  when sewage is not incoming, the pumping plant terminates its operation. When rain resumes, a quantity of sewage  $Q_x$  gradually fills the reservoir and turns on a pump at point H of the pump's flow characteristic. As more sewage flows in  $Q_x$  than escapes  $Q_1$ , the working point of the pump shifts towards declining heads. Point F corresponds to level S3 of sewage in the reservoir. Upon a time delay  $\Delta t$ , another pump is switched on at point B. The plant's capacity at C of  $H_2(Q)$  is then  $2Q_{1\max}$ , greater than the incoming sewage  $Q_x$ . As more sewage flows out, its

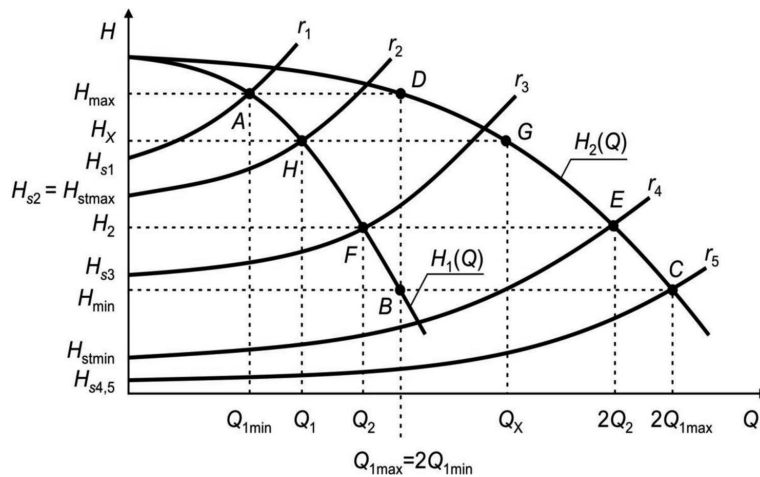

Fig. 4. Flow characteristics of a pump  $H_1(Q)$  and of two pumps in parallel  $H_2(Q)$

level in the reservoir diminishes. This state continues until G, where incoming and outflowing sewage are identical. The plant's operation is continuous after that. If the incoming sewage reduces to  $Q_2$ , its level drops and the plant's head reaches the point D. After a time delay  $\Delta t$  the pumps are switched off due to the risk of dry operation. As sewage continues to flow in, its level climbs and causes the pump to turn on at H. The pump's capacity  $Q_2$  ultimately equals the sewage quantity at F. This operating system of a pumping plant obtains where the variation range of a pump's head allows capacities at B and D to meet the condition  $Q_D \leq Q_B$ , that is:

$$Q_{1\max} \geq 2Q_{1\min} \quad (4)$$

### 3. Efficiency of a Pumping System in Cascade Regulation

In line with the principle of cascade regulation, switching of pumps depends on sewage levels in the storage reservoir. A pump is on when the level is maximum and a pumping system  $r_1$  is characterised by (Fig. 5):

$$H = H_{st\min} + aQ^2 \quad (5)$$

where:

$H_{st\min}$  – minimum static head of pump.

When the pump is off, the acceptable water level is minimum and the pumping system  $r_2$  is characterised by [5]:

$$H = H_{st\max} + aQ^2 \quad (6)$$

where:

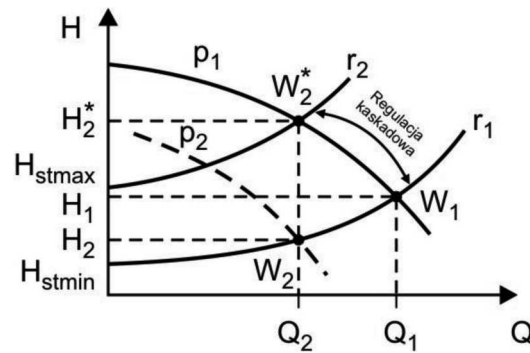

Fig. 5. Flow characteristic of a pump  $p_1$  relative to a reference curve  $r_1$  of a pumping system

$H_{st\ max}$  – maximum static head of pump.

As the water level in the storage reservoir declines, the pump's working point shifts from  $W_1$  to  $W_2^*$  (Fig. 5). The static head of pump increases, which results in reduced  $Q$  and shifting of the pump's working point towards greater heads. The changed working point of the pump is caused by characteristics of the pumping system shifting towards greater head values. This increases hydraulic losses due to an adopted method of control. A loss ratio  $\zeta_{kas}$  for cascade regulation has therefore been defined as:

$$\zeta_{kas} = \frac{H_2^* Q_2}{H_1 Q_1} - 1 \quad (7)$$

where  $\zeta_{kas} < 0$ , the hydraulic power for the working point  $W_2^*$  is lower than for  $W_1$ . This condition is fulfilled for:

$$H_2^* < \frac{Q_1}{Q_2} H_1 \quad (8)$$

Fulfilment of (8) is theoretically possible yet in practice considerably reduces efficiency of the pump and motor. In effect, this increases consumption of electric power.

In accordance with Fig. 5, it is assumed that pump operation along the characteristic  $r_1$  of a pumping system is acceptable. This will occur where a maximum sewage level is maintained in the storage reservoir and pump capacity is regulated by rotational speed variations. The characteristic  $r_1$  becomes then a reference curve, relative to which losses in cascade control are determined:

$$\zeta_{kas} = 1 - \frac{H_2}{H_2^*} \quad (9)$$

The (9) implies that the greater the difference of head for the same capacity, the greater the hydraulic losses in cascade control. This indicates that regulation of a pump's rotational speed in such a way that the pump operates along the reference curve may be of advantage.

#### 4. Variable-Rotational Control System of Sewage Pumping Plant's Operation

A sample sewage pumping plant, with a pump in dry operation, is illustrated in Fig. 6. A suction branch is immersed in a storage reservoir into which sewage flows with capacity  $Q_x$ . The pump changes the level of sewage in the reservoir from a minimum  $H_{z\min}$  to a maximum  $H_{z\max}$ . The pumped sewage flows through the pumping pipe out to a collector with capacity  $Q_o$ . Dynamic head losses  $\Delta H = aQ_o^2$  arise from the flow of sewage. Figure 6 implies  $H_t$  in the pumping branch meets the dependence:

$$H_t = H_{st} + aQ_o^2 \quad (10)$$

The following equation also holds true:

$$H_t = H + H_z \quad (11)$$

where:

$H_z$  – head of sewage in relation to the pump's horizontal axis.

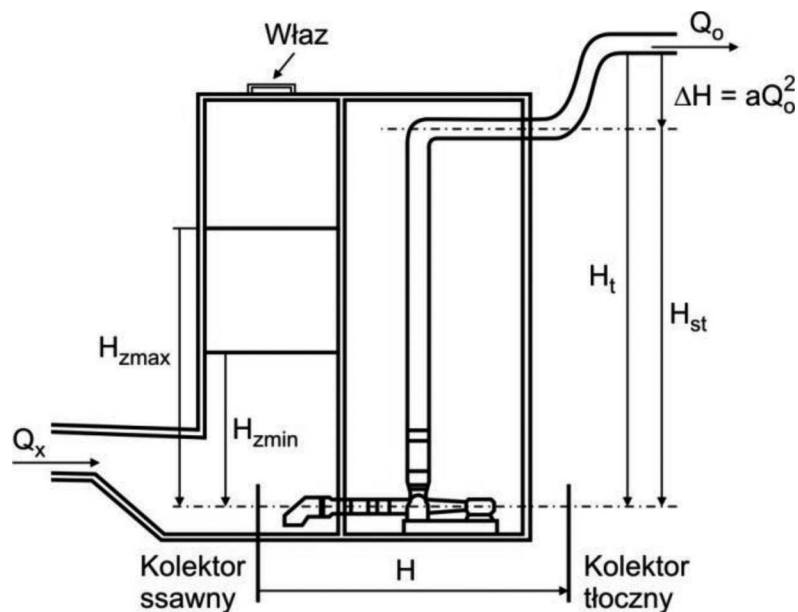

Fig. 6. A sample distribution of head across a sewage pumping plant

(11) implies that the greater  $H_z$ , the lower the head of pump,  $H$ . This translates into a reduced demand for electricity by the pump's electric motor. Figure 5 shows  $Q_2$  of the pumping plant is identical for working points  $W_2$  and  $W_2^*$ .  $H_2^*$  of the pump is greater for  $W_2^*$ , which means increased electricity requirements. At  $W_2^*$ ,



the pump operates at a rated rotational speed along the flow characteristic  $p_1$ . The operation along the flow characteristic  $p_2$  for a lower rotational speed  $n < n_N$  reduces consumption of electric power. To achieve this effect, the pump's operation should be controlled in such a manner that sewage level in the storage reservoir is maintained at its maximum. Since the inflow of sewage is stochastic, additional conditions must be met to assure proper operation of the entire pumping system:

- slowly coming sewage cannot be allowed to putrefy,
- a minimum capacity of a pumping plant should provide for a sufficient rate of sewage flow across the pumping branch so that solid particles are in motion,
- a maximum capacity of a pumping plant should not admit of excessive sewage flow rate that would result in excessive dynamic pressure losses,
- the range of the pump's capacity variations should be in line with manufacturer's recommendations in order to fulfil the criterion of reliable operation,
- such other conditions as are characteristic for a transported medium to ensure safe and reliable pumping.

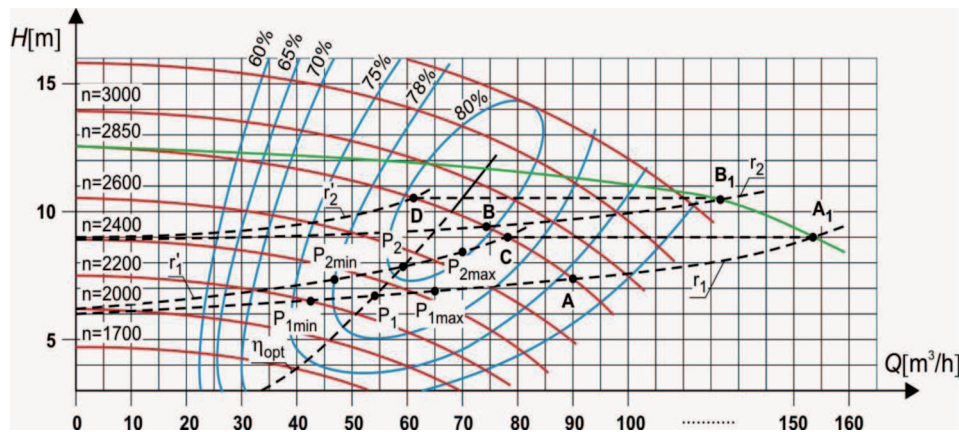

Fig. 7. Analysis of a sewage pumping plant's operation on the basis of the pump's iso-efficiency curve

Variations of  $Q$ ,  $H$  and  $\eta$  for a cascade and converter control system are illustrated on the basis of an iso-efficiency curve (Fig. 7). It is assumed that the pump's operation changes the sewage level in the storage reservoir by 3m, which causes the static head to be in the range  $H_{st} \in (6-9)\text{m}$  for  $Q = 0$ .

When a single pump operates under cascade control, its working point shifts along the flow characteristic from A to B for  $n_N = 2850[\text{rpm}]$ . Point A is determined by the characteristic of the pumping system  $r_1$ , whereas B is part of the characteristic  $r_2$ . The iso-efficiency curve suggests a range of variations of:

- capacity  $Q_{AB} \in (Q_A - Q_B) \approx (1.1-1.39)Q_{opt}$ ,
- pump efficiency  $\eta_{AB} \in (72\% \div 81\%)$ .

$\eta_{AB}$  variations can be treated as insignificant and acceptable in practical applications.

The range of capacity variations, on the other hand, is excessive as cavitation may occur [8, 9, 10]. Depending on characteristics of a pump's reliability, its capacity should be within the range  $Q \in (0.7-1.15)Q_{opt}$ . In practice, it is assumed that the pump's capacity should be within:  $Q \in (0.8-1.2)Q_{opt}$ . In the case under analysis, the optimum pump capacity is:  $Q_{opt} = 67[\text{m}^3/\text{h}]$ . The acceptable range of pump capacity variations is therefore:  $Q \in (54-80)[\text{m}^3/\text{h}]$ . The range of  $Q_{AB}$  variations is proof that the pump is liable to cavitation. The latter boosts wear and tear of the rotor, reduces the pump's efficiency, and consequently accelerates its overhaul. The effect can be eliminated where a pump operates at point  $P_1$  in the similarity parabola of optimum efficiencies  $\eta_{opt}$ . In the vicinity of  $P_1$ , pump efficiencies vary negligibly, its capacities can be therefore assumed to fall between  $P_{1min}$  and  $P_{1max}$ , where:  $QP_{1min} = 0.8QP_1 \approx 43[\text{m}^3/\text{h}]$  and  $QP_{1max} = 1.2QP_1 \approx 65[\text{m}^3/\text{h}]$ . In the capacity range  $Q \in (QP_{1min}-QP_{1max})$ , the pump operates at the highest sewage level in the storage reservoir  $H_{z,max}$ , which provides for energy savings compared to the parallel capacity range in the characteristic of the pumping system  $r_2$ .

Two pumps operate along a summary flow characteristic of the pumps between  $A_1$  and  $B_1$ . This means that working points of each pump are located between C and D, parts of pump flow characteristics determined in respect of a rated rotational speed  $n_N$  and characteristics of the pumping system,  $r_1'$  and  $r_2'$ . Capacity between C and D varies in the range:  $Q_{CD} \in (0.9-1.16)Q_{opt}$ , and efficiency is within the range:  $\eta_{CD} \in (79\%-82\%)$ . Operation between CD is effective in terms of energy and meets the criterion of high reliability at a rated rotational speed.

Changing the rotational speed to a value indicated by  $P_2$  provides for additional energy savings on lower heads of pump.  $P_2$  corresponds to  $QP_2 = 58[\text{m}^3/\text{h}]$  and is part of the similarity parabola including optimum pump efficiencies. Allowing for negligible variations of the pump efficiency, capacities in the following range of the pumping system characteristic  $r_1'$  were obtained:  $\Delta P_2 \in (QP_{2min}-QP_{2max}) \approx (0.8-1.2)QP_2 = (46-70)[\text{m}^3/\text{h}]$ . The adopted range of pump capacity variations can provide for a balance between the incoming sewage  $Q_x$  and capacity of the pumping plant  $Q_o$  while meeting the criterion of high energy efficiency.

## 5. P&ID Diagram of a Pumping Plant

A piping and instrumentation diagram for a variable speed controlled pumping plant is shown in Fig. 8. When pumps are controlled by variations of rotational speed, the latter's value is assumed to be restricted to the range:  $n^* \in (n_{min}^*; n_{max}^*)$ . Pumps then operate at maximum efficiencies for  $H = H_{zad} = \text{const}$ . The range of rotational speed variations depends on the minimum acceptable efficiency  $\eta_{min}$  of a pump [11] and also determines a range of the pump capacity variations  $Q \in (Q_{min}; Q_{max})$ . If the quantity of incoming sewage  $Q_x$  is within a recommended range of pumping plant capacity and its level in the storage reservoir reaches the rated maximum

$H_{z,max}$ , the operation of a pumping unit is continuous. (11) implies a pump's head is minimum then. This also signifies a minimum electricity requirement.

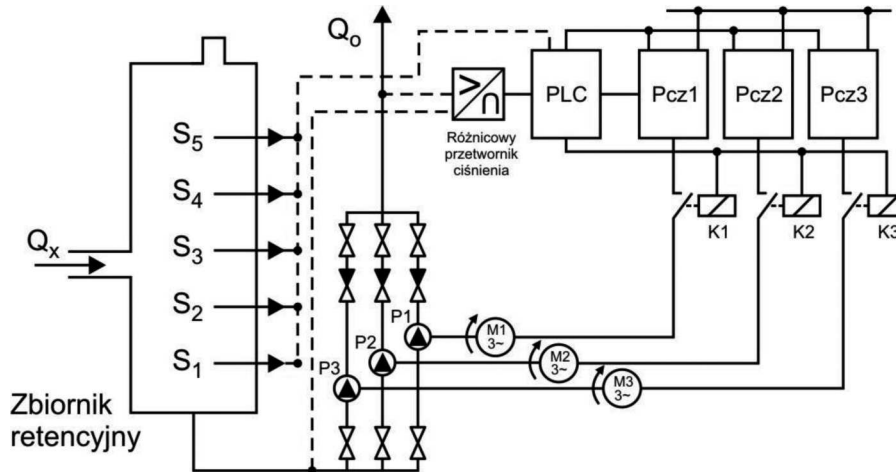

Fig. 8. A piping and instrumentation diagram for a variable speed controlled pumping plant

For a quantity of sewage  $Q_x$  below the minimum  $Q_{min}$ , the guiding pump is in intermittent operation. When the guiding pump reaches  $Q_{min}$  and the head of sewage is below  $H_{z,max}$ , the pump is switched off (for  $S_5$  – Fig. 2). When pumps are off, the sewage level in the reservoir rises. If it reaches a maximum, the guiding pump is on, the pumping plant's capacity  $Q_o$  increases and the head of sewage reduces. Variations of the sewage head in intermittent operation are in the range  $H \in (H_{z,min}-H_{z,max})$ . Pumps operate then at rotational speeds which provide for a maximum efficiency  $\eta_{opt}^*$  [11]. Frequency of the intermittent operation may be reduced where the guiding pump operates at a variable rotational speed in the range  $n^* \in (n_{min}^*; n_{max}^*)$ . Pumping plant's operation with a variable sewage level in the storage reservoir can increase energy consumption of the pumping and reduce reliability of the plant. This requires a detailed engineering and economic analysis.

## 6. Conclusions

The well-known cascade system for controlling operations of sewage and combined sewage pumping plants involves switching of pumps dependent on levels of sewage in the storage reservoir. Varying rotational speed of pumps enables to maintain a steady level of sewage and helps to reduce a pumping plant's electricity requirements. In addition, operation of pumps at variable sewage levels helps to select rotational speeds to assure maximum efficiency of pump operation. The method of controlling a pumping plant's operation proposed here is original and requires verification in actual facilities.

## References

1. Butler D., Davies W.: *Urban Drainage*, Third edition, Abidgon Spon Press, 2011.
2. Edel R.: *Odwodnienie dróg*, Warszawa: WKŁ, 2000.
3. Szling Z., Paczeński E.: *Odwodnienia budowli komunikacyjnych*, Wrocław: Oficyna Wydawnicza Politechniki Wrocławskiej, 2004.
4. Kisilowski J.: *Dynamika układu mechanicznego pojazd szynowy-tor*, Warszawa: PWN, 1991.
5. Jędral W.: *Pompy wirowe odśrodkowe, Teoria, Podstawy projektowania, Energooszczędna eksploatacja*, Warszawa: Oficyna Wydawnicza Politechniki Warszawskiej, 1996.
6. LFP Leszczyńska Fabryka Pomp, „Przepompownie ścieków PS,” 2012.
7. Smith P.N.: *Highway stormwater pump station design*, U.S. Department of Transportation, 2001.
8. Barringer H.P., Weber D.P.: „Life Cycle Cost Tutorial,” in *Fifth International Conference on Process Plant Reliability*, Houston, 1996.
9. Barringer H.P.: „Life Cycle Cost and Good Practices,” in *NPRA Maintenance Conference*, San Antonio, 1998.
10. Barringer H.P.: „A Life Cycle Cost Summary,” *International Conference of Maintenance Societies*, Perth, 2003.
11. Szychta L.: *Zasady doboru systemu sterowania pompowni wodociągowych*, Radom: Zakład Poligraficzny Politechniki Radomskiej, 2006.
12. Chudzicki J.: *Modelowanie strukturalne pompowni wodociągowych w aspekcie ich badań eksploatacyjnych*, Warszawa: Rozprawa doktorska, 2000.